

Iwaki Hi-Resolution Pump

HRP (Standard)

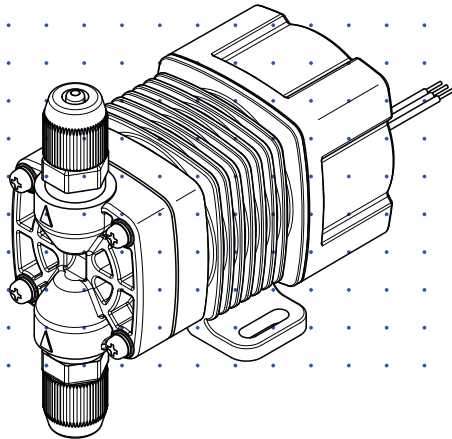

Instruction manual

Thank you for choosing our product.



Please read through this instruction manual before use.



This instruction manual describes important precautions and instructions for the product. Always keep it on hand for quick reference.

Order confirmation

After unpacking, check the following points. Contact us or your nearest dealer if the delivery is imperfect.

a. Check if the delivery is as per order.

Check the nameplate to see if the discharge capacity, discharge pressure and voltage are as per order.

Iwaki Metering Pump 			
MODEL			
CAPACITY	m ³ /min	MAX.PRESSURE	MPa
STROKE RATE	spm	VOLTAGE	V
CURRENT	A	POWER CONSUMPTION	W
MFG.No.			
IWAKI CO.,LTD. TOKYO JAPAN			 1F4224894

b. Check for transit damage.

c. Check for loose screws.

Delivery should include...

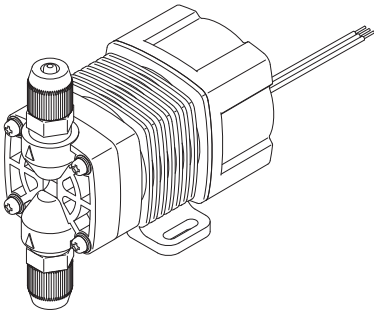

HRP with a special power cable



Instruction manual

Contents

Order confirmation	2
--------------------------	---

Safety instructions 5

WARNING.....	6
--------------	---

CAUTION	7
---------------	---

Precautions for use	9
---------------------------	---

Outline 11

Introduction	11
--------------------	----

Pump structure & Operating principle	11
--	----

Features	12
----------------	----

Operational function	12
----------------------------	----

Part names.....	13
-----------------	----

Identification codes.....	14
---------------------------	----

Installation 15

Pump mounting.....	15
--------------------	----

Pipework	16
----------------	----

Tube connection	16
-----------------------	----

Check valve mounting	17
----------------------------	----

AVC check valve with an air vent (Option).....	19
--	----

Wiring.....	20
-------------	----

Power & External signal cables	20
--------------------------------------	----

Operation 24

Before operation	24
------------------------	----

Points to be checked	24
----------------------------	----

Retightening of pump head unit fixing screws	24
--	----

Degassing.....	25
----------------	----

Operation	27
-----------------	----

Operation of the Pulse control type.....	27
Operation of the 4-20mA control type.....	27
Operation of the 1-5V control type.....	28
Operation of the STOP control type.....	28
Flow rate adjustment	29
Relation between the flow rate & stroke rate	29

Maintenance..... 30

Troubleshooting..... 30

Inspection.....31

Daily inspection	31
Periodic inspection	32
Before a long period of stoppage	32

Wear part replacement..... 33

Wear part list.....	33
Before replacement	34
Pump head/Diaphragm replacement.....	34

Maintenance (AVC check valve).....37

Exploded view (AVC check valve)	37
Wear parts list (AVC check valve)	38
Wear parts replacement (AVC check valve).....	38

Exploded view..... 42

Pump head, Drive unit & Control unit	42
--	----

Specification/Outer dimension 43

Specification	43
Pump & Drive units.....	43
Control unit.....	43
Power cable.....	43
Option	44
Check valve with an air vent.....	44
Check valve.....	44
Outer dimension	45
HRP-54V	45
HRP-54H.....	45

Safety instructions

Read through this section before use. This section describes important information for you to prevent personal injury or property damage.

■ Pictorial indication

In this instruction manual, the estimated risk of degree caused by incorrect use is ranked with the following pictorial indications. First, fully understand information on the pictorial indications.



WARNING

Indicates mishandling could lead to a fatal or serious injury accident.



CAUTION

Indicates mishandling could lead to personal or property damage.

Pictorial indication accompanies each precaution, suggesting "Caution", "Prohibition" and "Requirement".

Caution marks



Caution



Electrical shock

Prohibition mark



Prohibition



Do not remodel

Requirement mark



Requirement



Wear protectors



Earthing



For exportation

Technology related to the use of goods in this instruction manual falls in the category of technology contained in the Foreign Exchange Order Attachment, which includes complementary export control of technology. Please be reminded that export license, which is issued by the Ministry of Economy, Trade, and Industry could be required, when this is exported or provided to someone even in Japan.

WARNING

Turn off power before work

Risk of electrical shock. Be sure to turn off power to stop the pump and related devices before work.



Electrical shock

Stop the operation

On sensing any abnormality or dangerous sign, suspend operation immediately and inspect/solve problems.



Requirement

Do not use the pump in anything other than a specified purpose

The use of the pump in any purpose other than those clearly specified may result in failure or injury. Use this product in a specified condition.



Prohibition

Do not modify the pump

Remodelling the pump carries a high degree of risk. We are not responsible for any failure or injury results from remodelling.



Do not remodel

Wear protective clothing

Always wear protective clothing such as an eye protection, chemical resistant gloves, a mask and a work cap during dismantlement, assembly or maintenance work.



Wear protectors

Do not damage the power cable

Do not pull or knot the power cable or place a heavy stuff on it. Damage to the power cable could lead to a fire or electrical shock.



Prohibition

Do not use the pump in a flammable atmosphere

Do not place dangerous or flammable goods near the pump for your safety.



Prohibition

CAUTION

A qualified operator only

The pump must be handled or operated by a qualified person with a full understanding of the pump. Any person who is not familiar with this product should not take part in operation or management.



Requirement

Use a specified power only

Do not apply any power other than the one specified on the nameplate. Otherwise, failure or fire may result.



Prohibition

Do not run pump dry

Do not run pump dry for more than 30 minutes (even when the pump runs for degassing). Otherwise, the pump head unit fixing screws may loosen, or the pump head unit and valve case may deform by friction heat, and consequently leakage results. Optimise your system in order for the pump not to run dry.



Caution

Do not wet electric parts or wiring

Risk of fire or electrical shock. Install the pump free from liquid spill.



Prohibition

Ventilation

Poisoning may result when handling a toxic or odorous liquid. Keep good ventilation in your operating site.



Caution

Do not install or store the pump in the following places where...

- Under a flammable atmosphere or in a dusty/humid place.
- Ambient temperature is beyond 0-40 degrees Celsius.
- Under direct sunlight or wind & rain.



Prohibition

Countermeasure against efflux

Take a protective measurement against an accidental chemical overflow results from pump or piping breakage.



Requirement

Observe the correct polarity

Otherwise the pump may fail.



Do not use the pump in a water place

The pump is not totally waterproof. The use of the pump in water or high humidity could lead to electrical shock or short circuit.



Wear part replacement

Follow instructions in this manual for wear part replacement. Do not dismantle the pump beyond the extent of the instructions.



Do no use a damaged pump

Using a damaged pump could lead to an electric leak or shock.



Disposal of the used pump

Dispose of any used or damaged pump in accordance with relevant regulations. Consult a licensed industrial waste products disposing company.



Keep the pump head unit securely fixed

Liquid may leak if pump head unit fixing screws are loose. Tighten the screws diagonally and evenly before initial operation. Also, periodically tighten the screws for the prevention of leakage.



Tightening torque: 0.7 N•m

Precautions for use

- Electrical work should be performed by a qualified operator. Otherwise, personal or property damage accident may result.



- Do not install the pump in the following places where...
 - Under a flammable atmosphere or in a dusty/humid place.
 - Under direct sunlight or wind & rain.
 - Ambient temperature is beyond 0-40 degrees Celsius.Protect the pump with a cover when installing it out of doors.

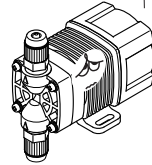
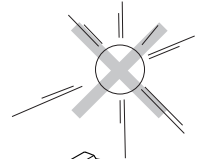

- Select a level location where is free from vibration and liquid can't stay. Fix the pump with M4 screws so as not to vibrate. If the pump is installed at a tilt, the flow may reduce.

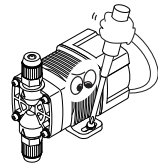

- When two or more pumps are installed, the pump operation interacts each other and vibration becomes significant, resulting in poor performance or failure of internal electrical devices. Select an installation location where tolerates vibration to enough degree.



- Keep a wide maintenance space around the pump.



- Install the pump as close to a supply tank.



- Install the pump in a cool and dark place when handling liquids that readily generate gas bubbles such as sodium hypochlorite or hydrazine solution. Flooded suction mounting is strongly recommended when using the pump with a supply tank.



- Be careful not to drop the pump onto the floor. A strong impact may reduce pump performance. Do not use a pump which has once damaged. Otherwise an electrical leak or shock may result.

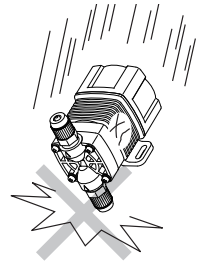

- The pump is a light water-/dust-proof structure of IP65, but is not totally waterproof. Do not have the pump wet with the liquid handled or rainwater.



- Never wet the pump head, control unit and drive unit. Otherwise, Failure or an accident may result. Immediately wipe off liquid if the pump has got wet.



- Do not close the discharge line during operation. Otherwise, liquid may leak or tubing may break.



- Do not remove the control unit. Otherwise, an electrical circuit or the drive unit may fail.



- Release the pressure from the discharge line before dismantling the pump or removing tubing. Otherwise, chemical liquid gushes out.



- Be careful not to come in contact with residual liquid.



- Do not clean the pump or nameplate with a solvent such as benzene and thinner. This may discolour the pump or erase printing. Use a dry cloth or a wet cloth with water or neutral detergent.

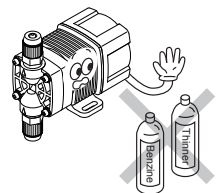

Outline

The information such as characteristics, features and part names are described in this section.

Introduction

Pump structure & Operating principle

The HRP series is a diaphragm metering pump which consists of a pump head, drive unit and control unit. A diaphragm is directly driven by electromagnetic force.

Principle of operation

The pulse signal controls the electromagnetic force in order to make reciprocating motion that is assisted by spring force. The reciprocating motion is transferred to a diaphragm through a plunger and then volumetric change occurs in the pump head. This action transfers liquid along with pump head valve action.

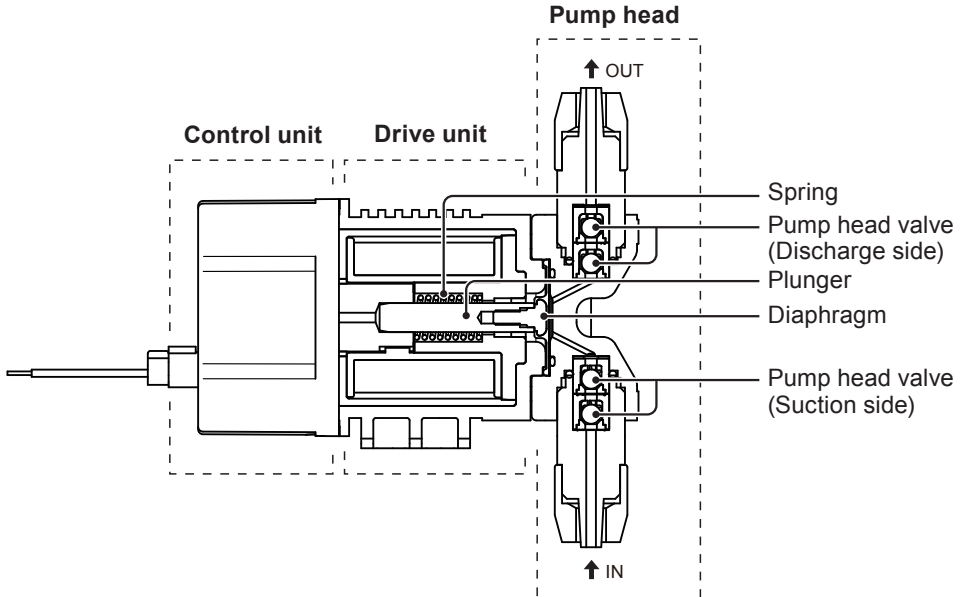

Features

12/24VDC power voltage

The HRP series powered by 12VDC or 24VDC offers the best fit to the built-in application.

High resolution

Digitally-controlled spm range is 0-720spm. The minimum flow of 0.055ml per shot offers a constant imperceptible injection.

*The operation speed of the stop control type is always fixed to 720spm and is not variable.

Waterproof and dustproof structure

The sealed drive unit and control unit assure the water-/dust-proof of IP65.

*This pump is not completely water resistant. Do not expose it to wind and rain.

Operational function

The HRP pump is controlled by the external signal and falls into the following types.

Pulse control type (see page 27)

The input of the pulse signal controls the pump operation (stroke rate).

The pump makes one shot per pulse synchronously.

*The signal input is required to make operation after power activation for this type.

*The pump can not run over 720spm even if the external signal is entered to run the pump beyond the maximum spm.

4-20mA control type (see page 27)

The input of 4-20mA proportionally controls the pump operation (stroke rate).

*The signal input is required to make operation after power activation for this type.

1-5V control type (see page 28)

The input of 1-5V proportionally controls the pump operation (stroke rate).

*The signal input is required to make operation after power activation for this type.

Stop control type (see page 28)

The input of the stop signal suspends the pump operation.

*This type of pump starts to run at 720spm upon power activation.

Part names

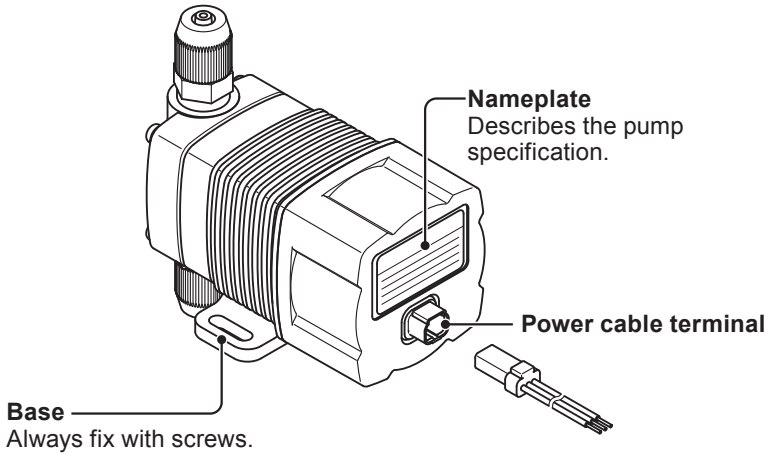
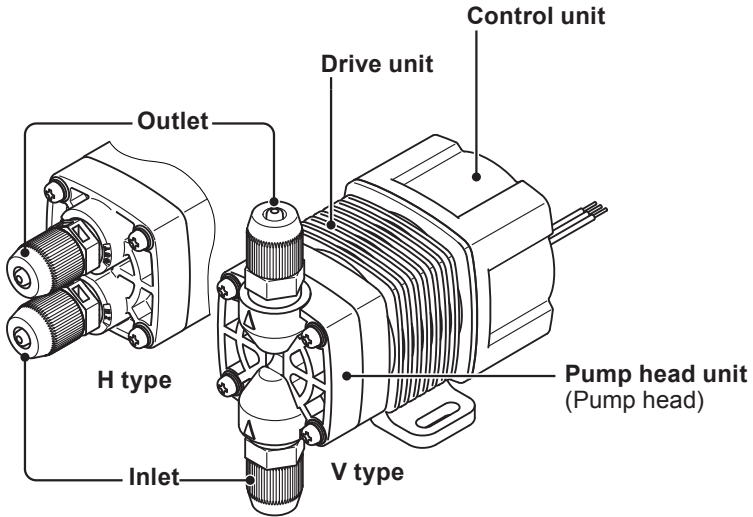

Identification codes

The model code represents the following information.

HRP - 5 4 V - 1 P 1 -
a b c d e f g H

a. Series name

HRP: High resolution pulse pump

b. Drive unit (Average power consumption)

5: 5.6W

c. Discharge capacity

4: 38ml/min

d. Pump head

V: Vertically oriented H: Horizontally oriented

e. Power voltage

1: 12VDC
2: 24VDC

f. Control method

P: Pulse control A: 4-20mA control V: 1-5V control S: Stop control

g. Connection bore

No.	Tube connection bore
1	ø3×ø6mm
2	ø4×ø6mm
3	ø1/8"×ø1/4"

H. Special version

Wet end materials

Pump head	Valve	O ring	Valve seat	Valve spring	Gasket	Diaphragm
PVDF	Alumina ceramic	FKM	FKM	PEEK (H type only)	PTFE	PTFE+ EPDM (non wet end)

*Valve springs are equipped to the H type only.

Material code

PVDF: Polyvinylidene difluoride FKM: Fluorine-contained rubber
PTFE : Polytetrafluoroethylene PEEK: Polyetheretherketone

Installation

This section describes the installation of the pump, tubing and wiring. Read through this section before work.

! Observe the following points when installing the pump.

- Be sure to turn off power to stop the pump and related devices before work.
- Upon sensing abnormal condition or a dangerous sign, stop the work immediately. Remove problems before resuming work.
- Do not place dangerous or flammable goods near the pump for your safety.
- Risk of an electrical leak or shock. Do not use a damaged pump.

Pump mounting

Select an installation location and mount the pump.

Necessary tools

- Two M4 screws (pump fixing)
 - Two plate washers (pump fixing)
 - Phillips screwdriver
- *Use chemical resistant tools as necessary.

1 Select a suitable place.

Always fix the pump on a flat floor where is free of vibration and liquid can't stay. See page 9 for detail.

Position the pump lower than the supply tank to assure flooded suction.

2 Fix the pump by M4 screws.

Be sure to fix the pump at two points.

NOTE

Install the pump horizontally. If the pump is installed at a tilt, the flow may reduces.

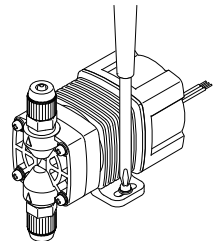

Pipework

Connect tubes to the pump and install a check valve.

Before operation

- Select proper chemical resistant tubes.
- The tubes should resist liquid temperature and pressure.
- Cut the tube ends flat.

Tube end (Side view)

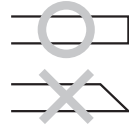

Tube connection

Pass a tube into the fitting nut and slide down the tube onto the fitting. Then hand tighten the fitting nut until it bottoms out.

*The fitting nut is made by plastics and may be broken if it is tightened too much.

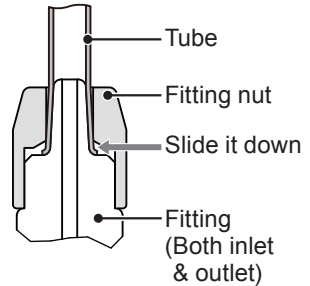

1 Connect tubes into the inlet and outlet.

*Be careful not to bend a tube completely.

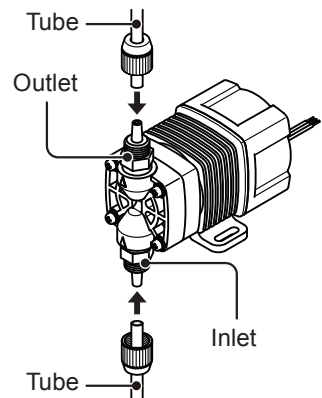
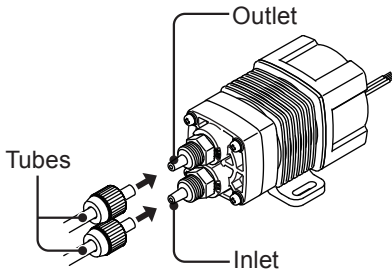

NOTE

Air vent valve mounting

- Install valves on both suction and discharge lines for the convenience of maintenance.
- Install a three-way joint on the discharge line close to the pump to lay on an air vent line.
- Keep a distance between the suction tube end and the tank bottom.
- In the suction lift application, install a foot valve for the prevention of a back flow at pump stop. A filtering foot valve is also available to prevent deposits and foreign matters from entering.

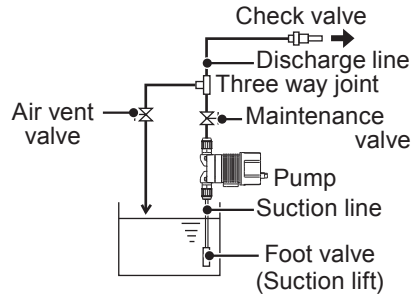

Check valve mounting

The use of a check valve prevents a back flow, siphon and overfeeding.

In the following cases install a check valve to assure back pressure and a constant flow rate.

- An injection point is below the suction side liquid level at atmospheric pressure. In this state siphon happens.

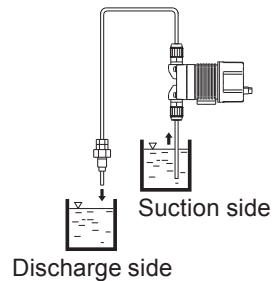

- The discharge side liquid level is higher than the suction side one but the elevation difference between two liquid levels is five meters or below. In this state the differential pressure between two liquid levels is too low and overfeeding happens.

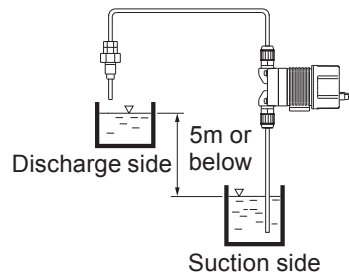

- Suction line pressure is higher than discharge line pressure. In this state siphon or overfeeding happens.

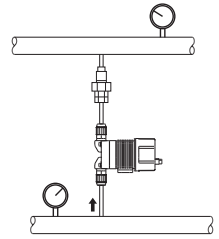

1 Mount the optional check valve at the discharge tube end.

*The CA check valve has R1/2 and R3/8 thread connections as well as tube connection. Cut off and adjust the connection length to fit the check valve into tubing.

CA check valve

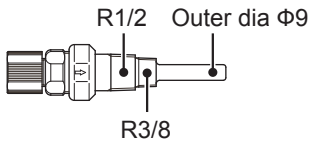

CB check valve

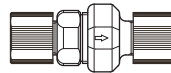

*Tubes can be connected to both ends of the CB check valve. Contact us or your nearest dealer for detail.

NOTE

Periodically clean or replace the check valve with new one because it may be clogged when handling sodium hypochlorite or other crystallizing liquids.

Tubing layout

Flooded suction application

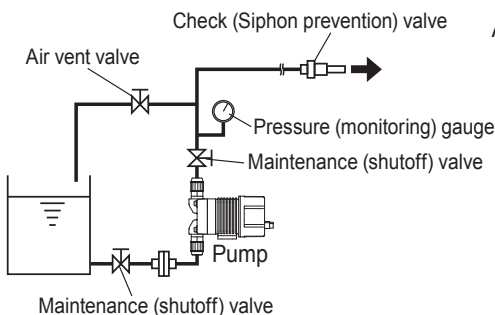

Suction lift application

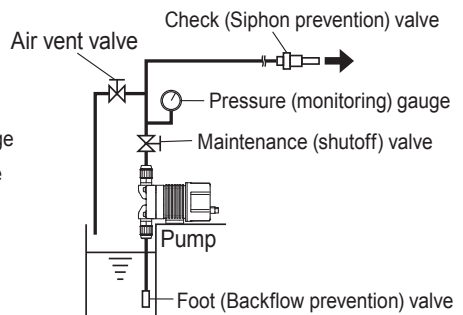

*Flooded suction is recommended when handling a gaseous liquid such as sodium hypochlorite.

AVC check valve with an air vent (Option)

AVC check valve is designed for being used with the HRP and works for both back-flow check and bleeding.

■ Specification

Model	Set pressure	Tube connection bore
AVC-FC1	0.1MPa	ø3×ø6mm
AVC-FC2		ø4×ø6mm
AVC-FC3		1/8"×1/4"

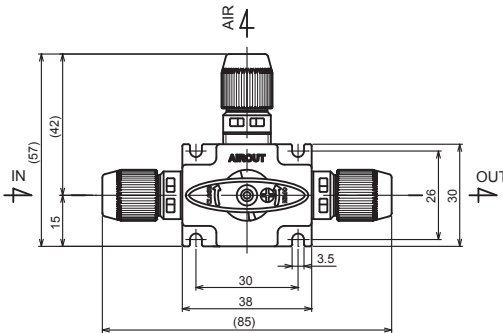

AVC air vent check valve

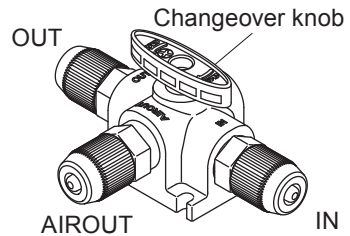

■ Back-flow check/Bleeding changeover

Select either function by rotating the changeover knob.

*The knob can rotate up to 270 degrees. A stopper is provided to determine the rotation limit of the knob.

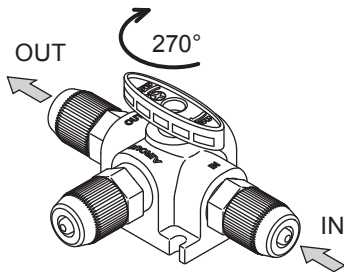

Back-flow check

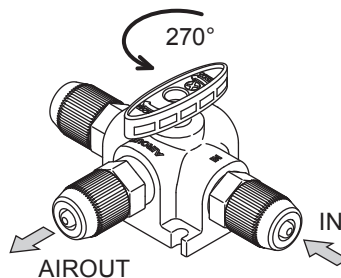

Bleeding

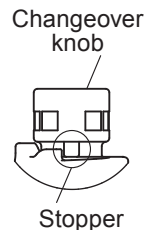

NOTE

Do not apply much stress to the stopper screw, or it may break.

Wiring

Wiring for the power source, earthing and external signal.

! Observe the following points during wiring work.

- Electrical work should be performed by a qualified operator. Always observe applicable codes or regulations.
- Observe the rated voltage. Otherwise the electrical circuit on the control unit may break.
- Do not perform wiring work while the power is on. Otherwise, an electrical shock and short circuit may result, and consequently the pump may fail. Be sure to turn off power before wiring work.
- Be careful for the power not to be turned on during work.
- Observe the correct polarity.
- Always use the attached triplex cable.
- Do not extend cable length more than 10m.
- Do not lay on the cable out of doors.

Power & External signal cables

Before work

- Check that the main power is turned off.
- Wait for one minute to start wiring work. The internal pump is still electrically charged right after power is turned off.

Applicable power cable

Use the attached triplex cable.

Triplex cable: UL3265 AWG22

Pink: +12VDC/+24VDC

Black: GND

White: EXT

*The attached triplex cable is designed for the HRP. Do not use another cable.

1 Remove the attached triplex cable from the control unit.

Unfasten a snap-fit connector and pull out the cable.

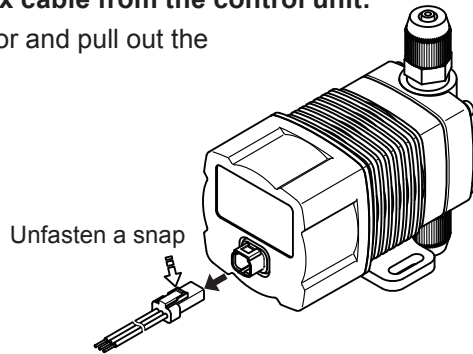

2 Connect power and external signal wires.

Observe the correct polarity.

Allocate pink and black wires for the power, and white and black wires for the external signal.

The black wire is common.

Wiring diagram

Pulse control type or Stop control type

The external signal should be either the no-voltage contact signal or open collector signal.

No-voltage contact signal

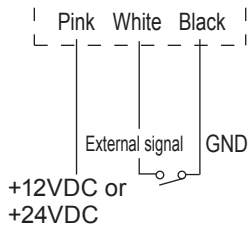

Open collector signal

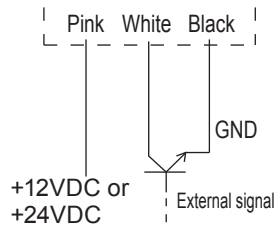

*Pulse width should be 10 - 50ms. The number of pulses should be 720 per minute or below.

4-20mA control type or 1-5V control type

Note that white wire is positive and black wire is negative.

4-20mA control type

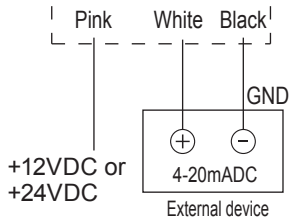

1-5V control type

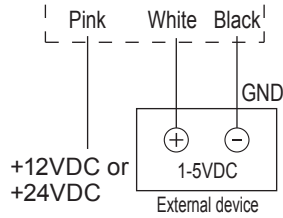

NOTE

- Secure correct polarity. Otherwise, pump failure may result.
- The external device for the 1-5V control type should have the current capacity of 25mA or more.

3 Attach the triplex cable to the control unit.

Push the snap-fit connector until it clicks one time.

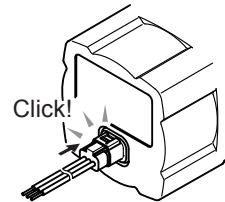

NOTE

- Always check the cable has been correctly secured to the control unit. Otherwise spilled chemicals may enter the inside of the pump.

NOTE

- Power voltage should be changed at a sitting via a switch or a relay. Otherwise CPU may malfunction. See below for the precautions for ON-OFF control by the relay.

When the power is applied at a sitting

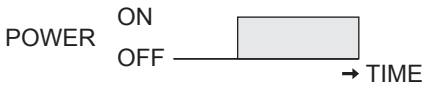

When the power is applied gradually



- Do not install the external signal wire in parallel with a power cable of another device. Otherwise the external signal wire is affected by induction effect and it results in pump malfunction or failure.
- When using the SSR (Solid State Relay) for the external signal input, see the recommended products below. Any SSR other than the recommended ones may result in malfunction. See manufacturer's information such as catalogues for detail.
 - OMRON G3FD-102S or G3FD-102SN
 - OMRON G3TA-IDZR02S or G3TA-IDZR02SM
- When using a contact type relay for the external signal input, the minimum application load should be 5mA or below.

Precautions for ON-OFF control by the relay

The control unit is equipped with a CPU. Always start/stop the pump by the external signal. Do not start/stop the pump by turning ON/OFF power because it may adversely affect CPU.

If there is no choice but to turn ON/OFF power, observe the following points.

- Do not turn ON/OFF the power more than six times per hour.
- When using a relay for ON-OFF operation, its contact capacity should be 5A or more. Contact point may fail if contact capacity is less than 5A.
- If the contact capacity of 5A is used for the HRP, the maximum ON-OFF operation is about 150,000 times. Use the relay with the contact capacity of 10A or more when making ON-OFF operation over 150,000 times or sharing a power source with a large capacity equipment. Otherwise a contact may fail by surge voltage.
- Use non contact transistor relay as necessary (ex. OMRON G3F). See manufacturer's catalogues for detail.

Operation

The pump becomes ready after pipework and wiring is completed.

This section describes pump operation and programming.

Before operation

Check the liquid level in the supply tank, tubing and wiring. And then perform degassing and flow rate adjustment before starting operation.

Points to be checked

Before operation, check if...

- Liquid level in the supply tank is enough.
- Tubing is securely connected and is free from leakage and clogging.
- Related discharge/suction valves are opened.
- Proper power voltage is applied to the pump.
- Electrical wiring is correct and is free from the risk of short circuit and electrical leakage.

Retightening of pump head unit fixing screws

Important

The pump head unit fixing screws may loosen when plastic parts creep due to temperature change in storage or in transit.

This can lead to leakage. Retighten the pump head unit fixing screws before starting operation.

Always tighten the screws diagonally, using a torque driver. See below for the tightening torque.

Tightening torque

Torque	Screw
0.7 N•m	M3 screw

*Tighten the fixing screws once every three months.

Use of a Phillips screwdriver instead of a torque driver

(a) Lightly tighten the pump head unit fixing screws until the sprig washer becomes flat. (b) Further turn the screws clockwise 180 degrees.

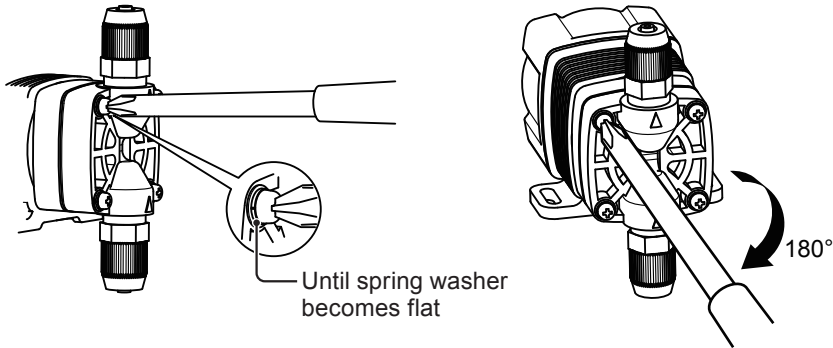

Degassing

The gas needs to be expelled from the pump and tubing by degassing. Normal operation can not be obtained with gas in the pump. Perform degassing in the following cases.

- When the pump starts to run for the first time
- When the flow rate is too low
- After liquid is replaced in the supply tank
- After a long period of stoppage
- After maintenance and inspection

NOTE

- Both gas and a chemical belch out together. Be careful not to be get wet with a chemical.
 - Place the end of air bleed tube in the supply tank or another container when the air bleed tube is attached via a three way joint.
 - Some chemicals may cause skin trouble or damage component parts. When your hand or component parts get wet with chemical liquid, wipe off immediately.
-

Install an air vent valve or AVC check valve on piping for degassing. Follow the procedure below to conduct degassing in case neither valve is available.

1 Connect a discharge tube and place the tube end in the supply tank or another container.

*Remove the check valve from the discharge tube if it is installed.

*When resuming the pump operation after liquid replacement in the supply tank or after a long period of stoppage, the internal pressure may remain in the pump or tubing. Removing the check valve at this state, liquid may gush out. Wrap a waste cloth around the check valve connection for the prevention of gushing.

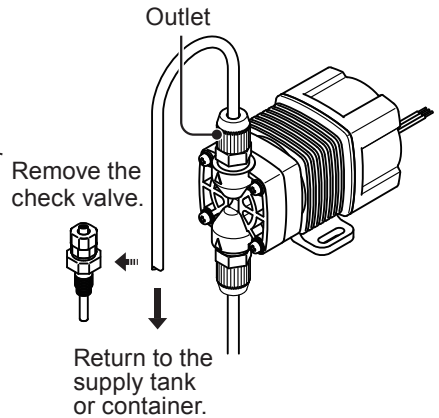

2 Turn on power.

Run the pump by the external signal.

*Run the pump at 600spm or more. Otherwise it takes longer time for the pump to expel gas.

3 Stop the pump.

4 Check that gas has been expelled from the pump head and liquid is pumped. Then reconnect the discharge tube to tubing system.

5 Check connections for leakage.

Degassing has now been completed.

Operation

This pump is controlled by the external signal. Read through this section for proper operation.

■ Operation of the Pulse control type

The input of the pulse signal controls the pump operation (stroke rate).

The pump makes one shot per pulse synchronously.

*The signal input is required to make operation after power activation for this type.

*The pump can not run over 720spm even if the signal is entered to run the pump beyond the maximum spm.

*Pulse width should be 10 - 50ms. Pulse period should be 83.3ms or more.

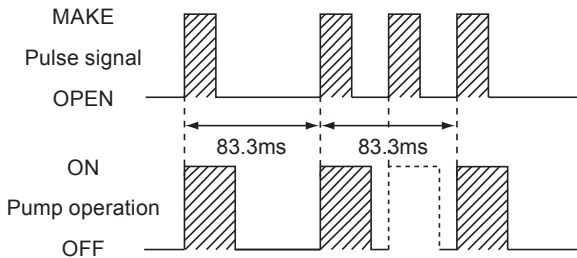

■ Operation of the 4-20mA control type

The input of 4-20mADC proportionally controls the pump operation (stroke rate).

A stroke rate decreases to 0spm at 4mADC and increases to 720spm at 20mADC.

*The signal input is required to make operation after power activation for this type.

*An input current should be in between 4 to 20mADC and should not exceed the range.

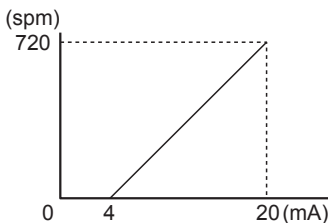

■ Operation of the 1-5V control type

The input of 1-5VDC proportionally controls the pump operation (stroke rate). A stroke rate decreases to 0spm at 1VDC and increases to 720spm at 5VDC.

*The signal input is required to make operation after power activation for this type.

*An input voltage should be in between 1 to 5VDC and should not exceed the range.

*The external device for the 1-5V control type should have the current capacity of 25mA or more.

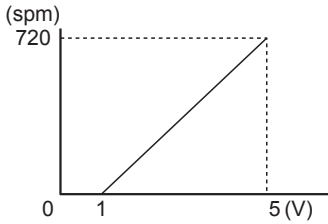

■ Operation of the Stop control type

The input of the stop signal suspends the pump operation.

*This type of pump starts to run at 720spm upon power activation.

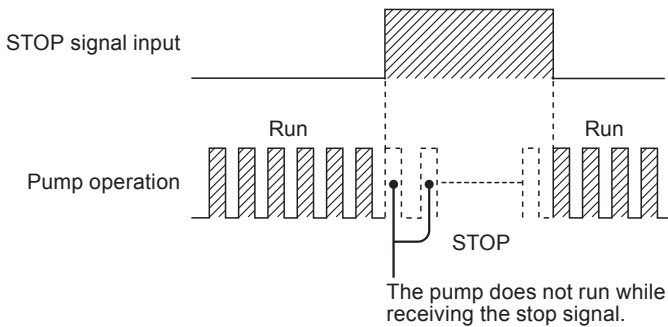

Flow rate adjustment

The flow rate is adjusted by the stroke rate.

The stroke rate is indicated in spm (stroke per minutes).

A stroke rate is determined by the number of external signals.

Determine a suitable stroke rate, taking account of the pump operating condition and liquid characteristics.

The following procedure is recommended.

- 1 Adjust a stroke rate to obtain a required flow rate.**
- 2 Measure a flow rate.**
- 3 If the flow rate is lower than a required level, increase a stroke rate and measure the flow again.**
- 4 Measure the flow again to see the required flow rate is obtained.**
Repeat this procedure until it reaches the required flow rate.

■ Relation between the flow rate & stroke rate

0-720spm can be programmed to the HRP.

The relation between the flow rate and stroke rate is as shown below.

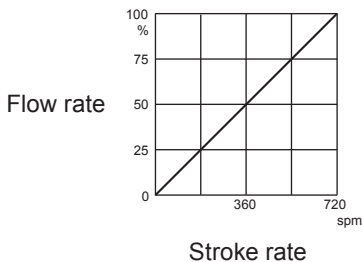

Maintenance

This section describes troubleshooting, inspection, wear part replacement, exploded views and specifications.

! Important

- Observe instructions in this manual for maintenance, inspection, dismantlement and assembly. Do not dismantle the pump beyond the extent of the instructions.
- Always wear protective clothing such as an eye protection, chemical resistant gloves, a mask and a work cap during dismantlement, assembly or maintenance work.
- Be sure to turn off power to stop the pump and related devices before work.

Troubleshooting

First check the following points. If the following measures do not help removing problems, contact us or your nearest dealer.

States	Possible causes	Solutions
The pump does not run.	Power voltage is too low.	• Recover the power voltage to a normal level. See page 43 for Allowable voltage deviation.
	The pump is not powered.	• Check the switch if it is installed. • Correct wiring. • Replace a breaking wire to new one.
	No signal input	• Check if the pump is receiving the external signal.
	The external signal is upset.	• See page 27.
	An electronic circuit in the control unit is failed.	• Replace the whole pump.
Liquid can not be sucked up.	Air lock in the pump	• Expel air. See page 25.
	Air ingress through a suction line.	• Correct tubing.
	A pump head unit is upside down.	• Correct its direction.

Liquid can not be sucked up.	Foreign matters are stuck in the pump head valves.	• Dismantle, inspect and clean the pump head unit. Replace as necessary.
	A ball valve is stuck on a valve seat.	
The flow rate fluctuates.	Air stays in the pump head.	• Expel air. See page 25.
	Overfeeding occurs.	• Mount a check valve. See page 17.
	Foreign matters are stuck in the pump head valves.	• Clean the pump head unit. Replace as necessary.
	A diaphragm is broken.	• Replace the whole pump.
	Pressure fluctuates at an injection point.	• Review tubing layout to maintain a pressure constant at an injection point or change an injection point in a constant pressure.
Liquid leaks.	Loose fit of the pump head unit.	• See page 24.
	A diaphragm is broken.	• Replace the whole pump.
	The discharge line pressure is too high.	• Check that a discharge line is not closed. • Check if tubing is not clogged.

Inspection

Perform daily inspection and periodic inspection to keep pump performance and safety.

Daily inspection

Check the following points. Upon sensing abnormal condition, stop the operation immediately and remove problems according to "Troubleshooting".

When wear parts come to the life limit, replace them by new ones. Contact us or your nearest dealer for detail.

No.	States	Points to be checked	How to check
1	Pumping	• If liquid is pumped.	Check flow meter.
		• If the suction and discharge line pressures are normal.	Check specification.
		• If liquid is deteriorated, crystallized or settled?	Visual or audio inspection
2	Noise and vibration	• If abnormal noise or vibration occurs. They are signs of abnormal operation.	Visual or audio inspection
3	Air ingress from pump head joints or a suction line	• If leakage occurs. • If discharge liquid includes air bubbles, check lines for leakage and retighten as necessary.	Visual or audio inspection

Periodic inspection

Retighten the pump head unit fixing screws diagonally every three months according to the following torque.

*Mounting screws may loosen in operation. How fast the screws start to loosen is depending on operating conditions.

Tightening torque

Torque	Screw
0.7 N•m	M3 screw

*A Phillips screwdriver can be used for a torque driver. See page 25.

Before a long period of stoppage (One month or more)

Clean the wet ends and tubing.

- Run the pump with clean water for about thirty minutes to rinse wet ends and tubing.
- Drain water or liquid from the pump after rinse is finished.

When the pump does not transfer liquid at resuming operation.

- Clean the wet ends by blowing air to remove foreign matters. Replace the pump head unit as necessary.
- If gas is in the pump head unit, expel gas and readjust the flow rate. See "De-gassing" on page 25 and "Flow rate adjustment" on page 29 for detail.

NOTE

- Residual liquid may spatter when blowing air. Wear protective clothing as necessary.
-

Wear part replacement



For a long operation wear parts need to be replaced periodically.

It is recommended that the following parts are always stocked for immediate replacement. Contact us or your nearest dealer for detail.

! Precautions

- When dismantling the pump, pay attention to the residual liquid in the pump.
- Rinse wet ends thoroughly with water.
- Each time wet ends are dismantled, replace the diaphragm and pump head unit with new ones.

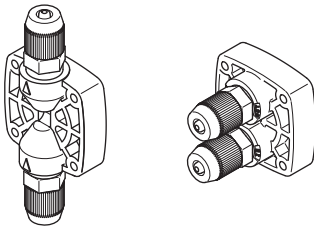
Wear part list

		Parts	# of parts	Estimated life
Pump	Pump head unit		1	8000 hours
	O ring		1	
	Diaphragm		1	

*Wear part duration varies with the pressure, temperature and characteristics of the liquid.

*The estimated life is calculated based on the continuous operation with ambient clean water.

*The whole pump needs to be replaced once the diaphragm is broken or damaged.

*Replace the pump head unit, O ring and diaphragm at the same time.

Before replacement

First release the pressure from the pump and discharge line. Otherwise, liquid may gush out.

1 Stop the pump operation.

2 Release the internal pressure.

Open the air vent valve if it is installed. If not, see page 25.

3 Check that liquid comes out from the air vent port and the internal pressure has been expelled.

NOTE

The internal pressure may not be expelled completely as long as liquid does not come out. In this case run the pump until the pressure is released.

Pump head/Diaphragm replacement

Dismantlement

1 Loosen the fitting nut and remove the discharge and suction tubes.

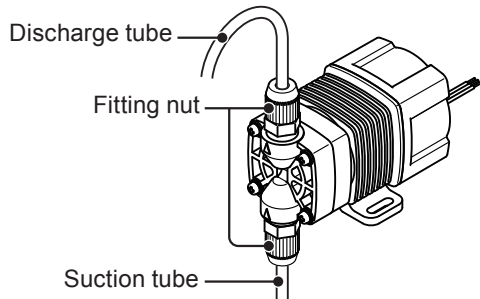

2 Detach the pump head unit.

Use a Phillips screwdriver or torque driver to remove four M3 screws.

- 3 Turn the diaphragm anticlockwise to detach it from the plunger.**

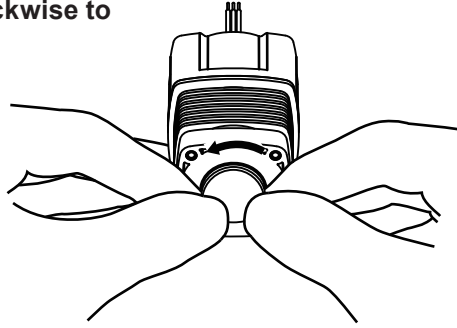

NOTE

Pay attention not to lose diaphragm spacers. Always apply a proper number of diaphragm spacers. 0 or a few diaphragm spacers are inserted between the retainer and plunger for the adjustment of diaphragm location. Note that the number of diaphragm spacers varies with pump model. Some pumps may use no spacer.

Assembly

- 1 Pass diaphragm spacers into the diaphragm shaft.**

Apply a proper number of diaphragm spacers.

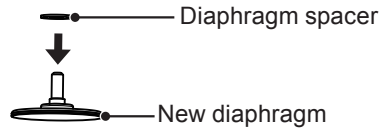

- 2 Fit the new diaphragm into the plunger.**

Put the pump vertically downwards and screw the diaphragm into the plunger with the proper number of diaphragm spacers.

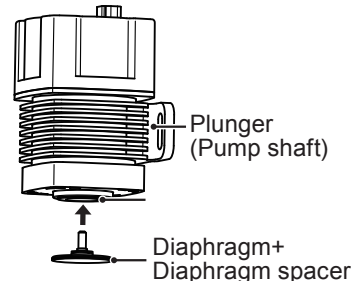

- 3** Turn the diaphragm clockwise to attach it to the plunger.

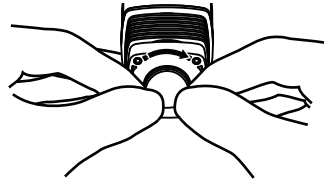

- 4** Place the O ring into the O ring groove on the pump head unit.

*Make sure the O ring does not stick out from the groove.

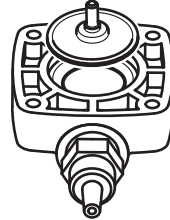
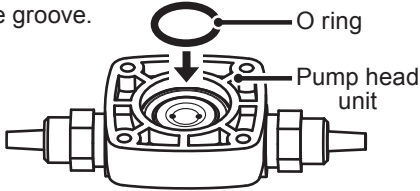

*When O ring can not fit in...
Place a used diaphragm on the O ring and push it down.

- 5** Attach the pump head unit.

Put a new pump head unit with a triangle mark upside. Tighten the four M3 screws to fasten the unit diagonally and evenly.

Tightening torque: 0.7N•m

*A Phillips screwdriver can be used for a torque driver. See page 25.

*Be careful not to strip the slot on screw heads.

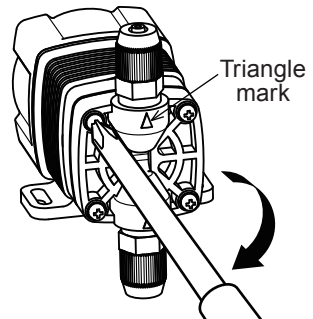

NOTE

Keep the pump head unit free from contaminations or foreign matters during work.

- 6** Attach the discharge and suction tubes and tighten the fitting nuts.

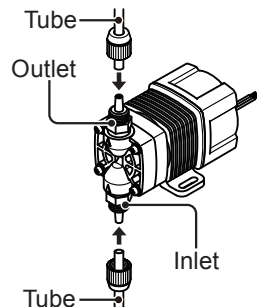
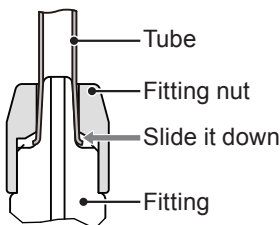

Maintenance (AVC check valve)

! Precautions

- When dismantling the check valve, pay attention to the residual liquid in the pump.
- Rinse wet ends thoroughly with water.

Exploded view (AVC check valve)

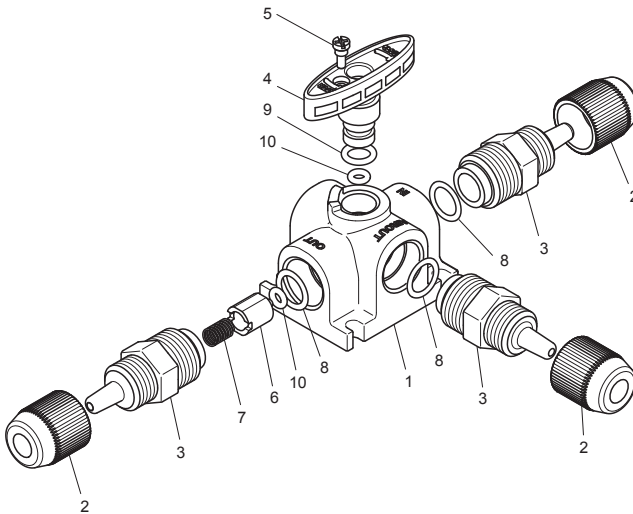

No	Part names	Q'ty
1	Body	1
2	Fitting nut	3
3	Fitting	3
4	Air vent valve	1
5	Stopper screw	1
6	Poppet valve	1
7	Spring	1
8	O ring	3
9	O ring	1
10	O ring	2

Wear part list (AVC check valve)

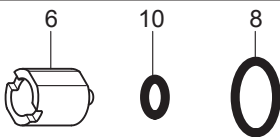
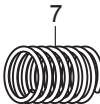
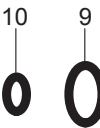
		Parts	# of parts	Estimated life
Pump	Poppet valve with O rings		1	8000 hours
	Spring		1	
	Orings		1	

*Wear part duration varies with the pressure, temperature and characteristics of the liquid.

*The estimated life is calculated based on the continuous operation with ambient clean water.

*Replace the poppet valve, spring and O rings at the same time.

Wear parts replacement (AVC check valve)

First release the pressure from the discharge line. Otherwise, liquid may gush out during work.

1 Stop the pump operation.

2 Release the internal pressure.

Turn the changeover knob and expel air from the air vent.

3 Check that liquid comes out from the air vent port and the internal pressure has been expelled.

Dismantlement

1 Detach the AVC check valve.

Loosen the fitting nut and remove tubes from the IN, OUT and AIROUT ports.

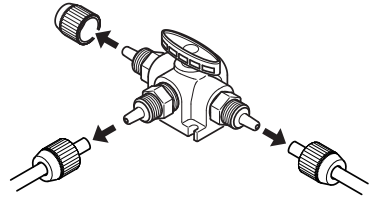

2 Remove the fitting nut.

Use an adjustable wrench or spanner to unscrew the fitting nut.

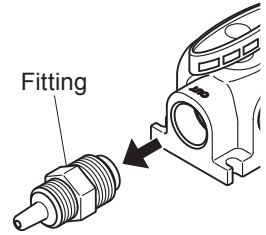

3 Take out a spring, poppet valve and O rings.

Use a pair of tweezers as necessary.

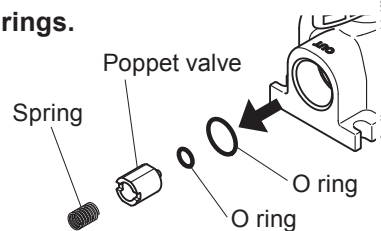

4 Fit a spring, poppet valve and O rings.

- Place a small O ring into the poppet valve.
- Insert the spring and poppet valve into the fitting.
- Fit the large O ring into the connecting port.
- Screw in the fitting.

*Tighten the fitting by $2.5\text{N}\cdot\text{m}$. If a torque wrench is not available, tighten the fitting hand-tight and then further rotate it by 90 degrees, using an adjustable wrench or a spanner.

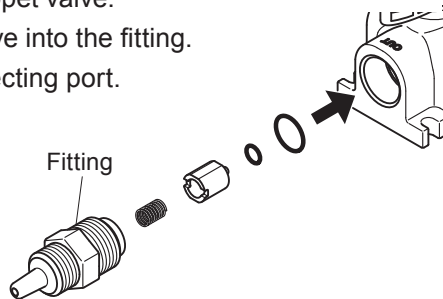

NOTE

- Do not insert poppet valve the other way around. Or a poor flow or a leak may result.
- Be careful not to forget to mount O rings.
- Keep the parts free from dust.

- 5** Unscrew the stopper from the changeover knob.

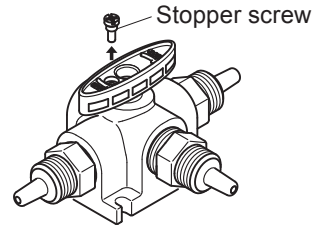

- 6** Unscrew the changeover knob.

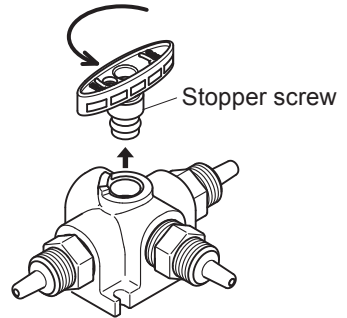

- 7** Detach O rings.

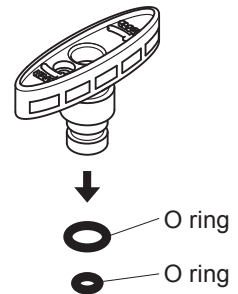

- 8** Attach new O rings.

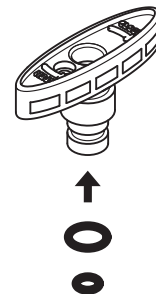

9**Screw in the changeover knob until it bottoms out.**

Do not tighten the knob too much so that the changeover knob stops at a rotation limit.

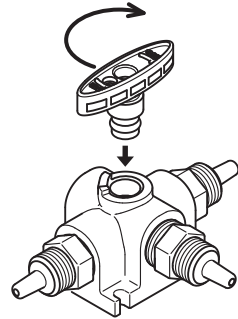
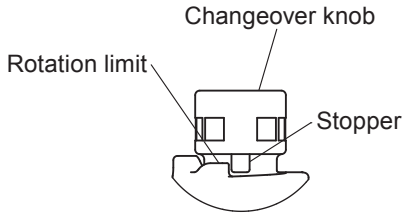
**10****Screw the stopper screw in the knob.**

Use a precision screw driver.

NOTE

Do not tighten the stopper screw too much. Or it may break.

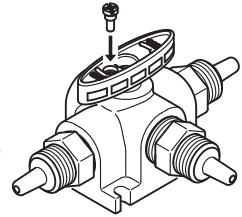
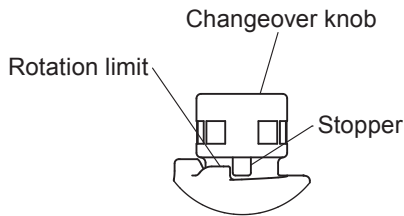
**11****Check the knob rotation is stopped by the rotation limit and stopper.****12****Connect IN, OUT and AIROUT tubes to each port.**

Exploded view

Pump head, Drive unit & Control unit

Observe instructions in this manual to dismantle the pump.

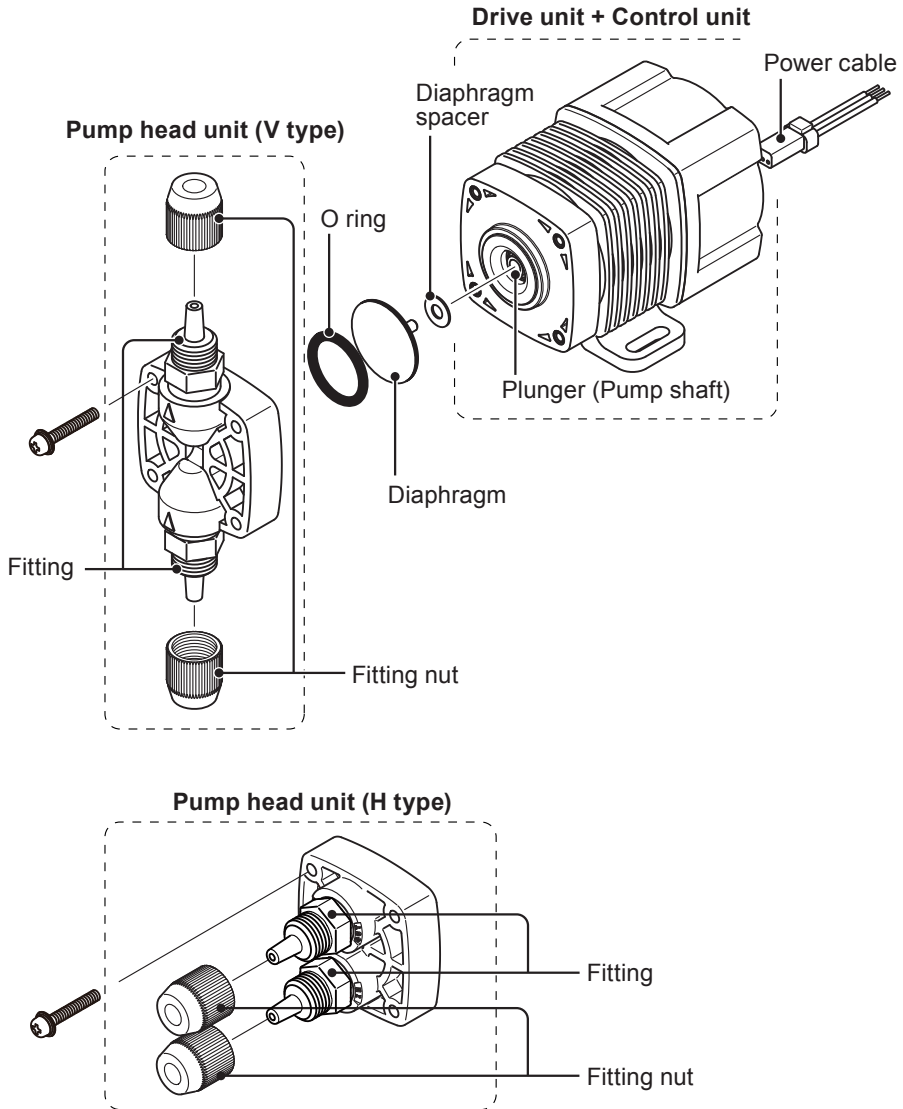

Specification/Outer dimension

Specification

■ Pump & Drive units

Model code	Flow rate	Max. discharge pressure	Stroke rate	Tube connection bore	Power voltage	Power consumption	Current value	Weight
HRP-54V/H-1	38 ml/min	0.2MPa	0-720spm	ø3×ø6mm ø4×ø6mm ø1/8"×ø1/4"	12VDC	5.6W	1.5A	0.5kg
HRP-54V/H-2					24VDC		1.0A	

*This specification is based on pumping clean water at ambient temperature and rated voltage.

*Flow rate is collected at the maximum discharge pressure and 720spm. The flow rate increases as a discharge pressure decreases.

*Allowable room temperature: 0-40°C

*Allowable liquid temperature: 0-40°C

*Allowable voltage deviation: ±5% of the rated voltage

12VDC: 11.4V-12.6V

24VDC: 22.8V-25.2V

■ Control unit

Pulse control type	Upper limit spm	720spm
	Operation	One shot per signal (Synchronous operation)*2
	Input signal	No-voltage contact or open collector*1
4-20mA control type	Upper limit spm	720spm
	Operation	4-20mADC proportional operation to 0-720spm
	Input signal	Current: 4-20mADC
1-5V control type	Upper limit spm	720spm
	Operation	1-5VDC proportional operation to 0-720spm
	Input signal	Voltage: 1-5VDC (Current capacity of 25mA or more)
Stop control type	Upper limit spm	720spm (Fixed)
	Operation	The pump stops during contact input.
	Input signal	No-voltage contact or open collector*1

*1 The maximum applied voltage to the contact is 12V at 5mA. When using a contact type relay, the minimum application load should be 5mA or below.

*2 When the external pulse signal is entered to run the pump over the upper limit spm, the signal is cancelled.

■ Power cable

Conduction section area	0.32 [mm ²] (Triplex cable)	Standard	UL3265
Length	600 [mm]	Terminal treatment	Bared

Option

■ Check valve with an air vent

Model code	Set pressure	Tube connection bore		Materials		
				Body	O ring	Spring
AVC-FC1	0.1MPa	ø3×ø6mm		PVDF	FKM	HC276
AVC-FC2		ø4×ø6mm				
AVC-FC3		ø1/8"×ø1/4"				

■ Check valve

Model code	Set pressure	Tube connection bore		Materials		
		IN	OUT	Body	O ring	Spring
CA-1VC-4×6	0.17MPa	ø4×ø6mm	R3/8", R1/2" (thread)	PVC	FKM	HC276
CB-1VC-4×6			ø4×ø6mm			

Material code

PVDF : Polyvinylidene difluoride

PVC : Transparent polyvinyl chloride

FKM : Fluorine-contained rubber

HC276 : HASTELLOY C276

Outer dimensions

■ HRP-54V

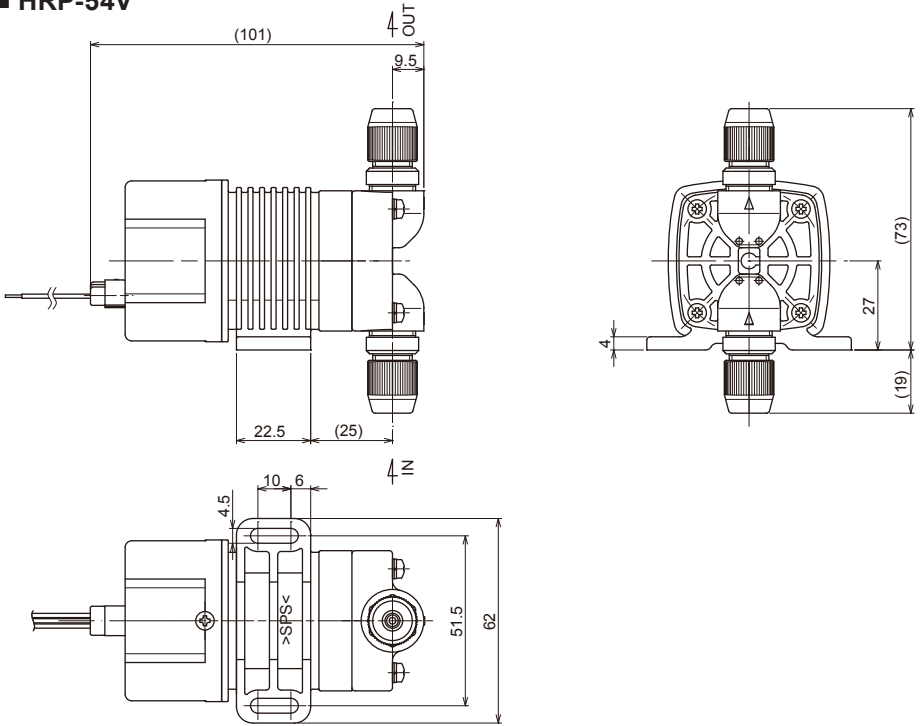

■ HRP-54H

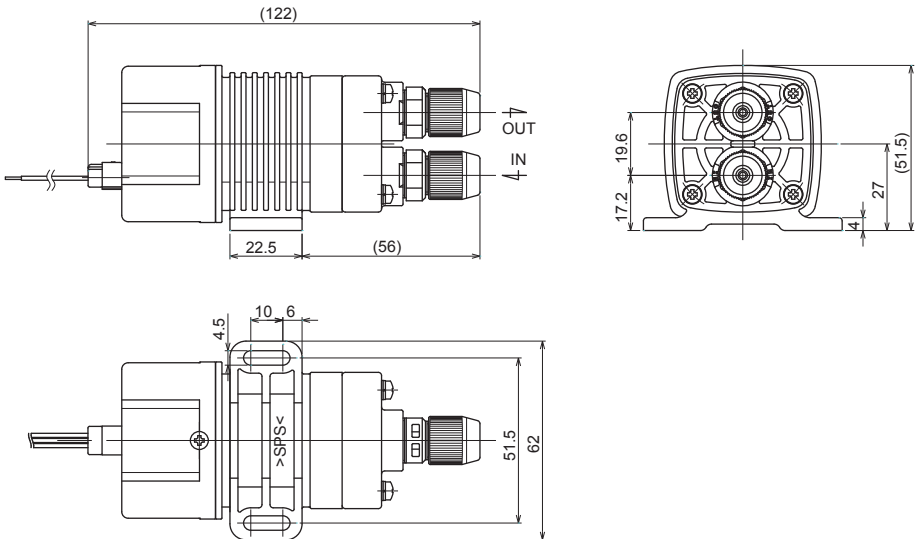

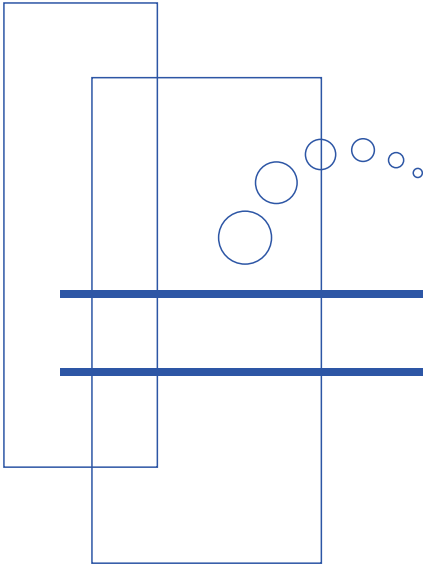

<http://www.iwakupumps.jp>

() Country codes

IWAKI CO.,LTD. 6-6 Kanda-Sudacho 2-chome Chiyoda-ku Tokyo 101-8558 Japan
 TEL:(81)3 3254 2935 FAX:3 3252 8892(<http://www.iwakupumps.jp>)

Australia	IWAKI Pumps Australia Pty. Ltd.	TEL: (61)2 9899 2411	FAX: 2 9899 2421	Italy	IWAKI Italia S.R.L.	TEL: (39)02 990 3931	FAX: 02 990 42888
Austria	IWAKI (Austria) GmbH	TEL: (43)2236 33469	FAX: 2236 33469	Korea	IWAKI Korea Co.,Ltd.	TEL: (82)2 2630 4800	FAX: 2 2630 4801
Belgium	IWAKI Belgium n.v.	TEL: (32)1367 0200	FAX: 1367 2030	Malaysia	IWAKIm Sdn. Bhd.	TEL: (60)3 7803 8807	FAX: 3 7803 4800
China	IWAKI Pumps (Shanghai) Co., Ltd.	TEL: (86)21 6272 7502	FAX: 21 6272 6929	Norway	IWAKI Norge AS	TEL: (47)66 81 16 60	FAX: 66 81 16 61
China	IWAKI Pumps (Guandong) Co., Ltd.	TEL: (86)750 3866228	FAX: 750 3866278	Singapore	IWAKI Singapore Pte. Ltd.	TEL: (65)6316 2028	FAX: 6316 3221
China	GFTZIWAKI Engineering & Trading (Guangzhou)	TEL: (86)20 8435 0603	FAX: 20 8435 9181	Spain	IWAKI Iberica Pumps, S.A.	TEL: (34)943 630030	FAX: 943 628799
China	GFTZIWAKI Engineering & Trading (Beijing)	TEL: (86)10 6442 7713	FAX: 10 6442 7712	Sweden	IWAKI Sverige AB	TEL: (46)8 511 72900	FAX: 8 511 72922
Denmark	IWAKI Nordic A/S	TEL: (45)48 24 2345	FAX: 48 24 2346	Switzerland	IWAKI (Schweiz) AG	TEL: (41)26 674 9300	FAX: 26 674 9302
Finland	IWAKI Suomi Oy	TEL: (358)9 2745810	FAX: 9 2742715	Taiwan	IWAKI Pumps Taiwan Co., Ltd.	TEL: (886)2 8227 6900	FAX: 2 8227 6818
France	IWAKI France S.A.	TEL: (33)1 69 63 33 70	FAX: 1 64 49 92 73	Taiwan	IWAKI Pumps Taiwan (Hsin-chuj) Co., Ltd.	TEL: (886)3 573 5797	FAX: (886)3 573 5798
Germany	IWAKI EUROPE GmbH	TEL: (49)2154 92540	FAX: 2154 9254 48	Thailand	IWAKI (Thailand) Co.,Ltd.	TEL: (66)2 322 2471	FAX: 2 322 2477
Holland	IWAKI Holland B.V.	TEL: (31)547 293 160	FAX: 547 292 332	U.K.	IWAKI Pumps (UK) LTD.	TEL: (44)1743 231363	FAX: 1743 366507
Hong Kong	IWAKI Pumps Co., Ltd.	TEL: (852)2 607 1168	FAX: 2 607 1000	U.S.A.	IWAKI AMERICA Inc	TEL: (1)508 429 1440	FAX: 508 429 1386
Indonesia	IWAKI Singapore (Indonesia Branch)	TEL: (62)21 690 6606	FAX: 21 690 6612	Vietnam	IWAKI Pumps Vietnam Co.,Ltd.	TEL: (84)613 933456	FAX: 613 933399